

# Radiola III

## INTRODUCTION

The RADIOLA III is a high grade regenerative radio receiving set especially designed for broadcasting reception. It uses two WD-11 Radiotrons which are arranged to operate as a detector and audio amplifier. Four antenna binding posts are provided so that a choice of two types of tuning circuit may be had. One is a sensitive single tuning circuit that has made an excellent reputation in the Radiola Senior, while the other is a more selective circuit for use when interference is present. The apparatus is mounted below an attractive horizontal panel of durable molded material and is enclosed in a solid mahogany case. A flexible cable is provided, by which all battery connections are made, thus, the set may be placed on a table while the batteries are placed on the floor or elsewhere out of the way.

## EQUIPMENT

### Material Furnished

Under the name of RADIOLA III, there is included the following material:

- RADIOLA III Receiving Set as described.
- Two RADIOTRONS, Type WD-11.
- One Telephone Headset.

### Additional Material Needed

To complete a new installation, the following material will also be needed:

Complete Antenna and Ground Outfit, A, B and C Batteries as follows:

- "A" Battery** for filament heating, consisting of from four to six  $1\frac{1}{2}$  volt dry cells connected in parallel, such as one of the following:
- 4 to 6 Eveready Radio "A" Batteries # 7111.
  - 4 to 6 Burgess "A" Batteries # 6.
  - 4 to 6 Ray-O-Vac "A" Dry Batteries # 1211.
  - 4 to 6 Manhattan Red Seal Dry Cells # 2445.
  - 4 to 6 Columbia Ignitor # 6 Dry Cells.

or any other make of good dry cell having approximate dimensions of  $2\frac{1}{2}$  inches diameter by 6 inches high.

A two volt (one cell, lead type) storage battery may be used.

**"B" Battery** for supplying power to the plate circuits, consisting of two  $22\frac{1}{2}$  volt plate batteries connected in series or of one 45 volt plate battery, such as one of the following:

- 2 Eveready # 766 Plate Batteries.
- 2 Burgess # 2156 Plate Batteries.
- 2 Ray-O-Vac # 2151 Plate Batteries.
- 2 Ace # 115 Plate Batteries.

or

- 1 Eveready # 767 Plate Battery.
- 1 Burgess # 2306 Plate Battery.
- 1 Ray-O-Vac # 2301 Plate Battery.

or any other good make of radio plate battery. The ones listed are of the large size which are most economical but the intermediate size may also be used.

**"C" Battery** for producing a negative grid potential, consisting of one  $1\frac{1}{2}$  volt dry cell. This may conveniently be the same as one of the cells of the "A" Battery and this is recommended.

## INSTALLATION

**Location**—The RADIOLA III should be placed as near as possible to the incoming wire from the antenna. A good ground, such as a water pipe, should be not far away. The set may be placed on a small table so that the batteries may rest on the floor or elsewhere out of the way.

### Antenna

**Outdoor Type**—In general, best results will be obtained with an outdoor antenna from 50 to 150 feet long and 20 or more feet above the ground. If these dimensions cannot be secured, approach them as nearly as possible. The antenna should be located in a space above the tops of surrounding buildings and in a space as free as possible from other objects. It should not be touched by any other object than the antenna insulators. The same precautions apply to the lead-in, which should preferably be a continuation of the antenna wire to eliminate joints, and should run as directly as possible to the receiver. The antenna should be at right angles to any electric light and other wires and if practicable, at least 15 feet distant from them and from other antennae. It should be erected in a strong and durable manner in accordance with the requirements of the National Electric Code.

**Indoor Type**—For local reception, and in some cases for distant reception, satisfactory results may be secured by using 20 to 40 feet of ordinary cotton covered magnet or bell wire (about 18 to 22 B & S gauge) strung around a picture moulding or elsewhere as high up as possible. This type of antenna is particularly suitable for use in apartment houses or similar buildings but will not give satisfactory results in steel frame buildings or in ones having metal lath under the plaster.

### Ground

A good ground is as necessary as a good antenna. The best ground is a good electrical connection to a water pipe. If this is not convenient, a connection to the steam or hot water heating system will usually serve almost as well. Connections to gas pipes should be avoided. If nothing of this nature is available, a pipe or metal rod may be driven into the ground to a depth of several feet, preferably where the soil is moist. The ground connection should be made with a ground clamp to which the wire is soldered or securely held by gripping under a screw or nut. In any case the pipe must be scraped or filed until clean and bright before attaching the ground clamp. Usually, connecting to more than one ground, for instance, to both water and steam pipes, will improve reception.

## Connections

Three separate batteries are needed to operate Radiola III. The "A" battery heats the filament of the Radiotrons, the "B" battery supplies the power to the plate circuits and the "C" battery controls the grid potential of the amplifier Radiotron so that amplification will be undistorted and the "B" battery will last longer.

The connection of these batteries may best be understood by reference to the diagram in Fig. 2. Near the center are shown two #6 dry cells marked "A Battery". These are to be connected in parallel, that is, the outside terminals are to be connected together by one piece of wire and the center terminals by another piece of wire. Under no condition must these two wires touch each other or the cells will be ruined in a few minutes. The Radiola III is provided with a five conductor cable, the lower end of which is shown at the top of figure 2. Each of the conductors has a braid of distinctive color which designates the purpose of that particular conductor. The one with the green field and yellow tracer which carries a small tag marked "-A+C" is to be connected to the negative side (outside terminals) of the "A" battery. It may be connected to either terminal or to the wire which connects them. The conductor having a yellow field with red and blue tracers is to be connected to the positive side (center terminals) of the "A" battery. It may be connected to either terminal or to the wire which connects them. Be sure to make all connections tightly and securely.

Before proceeding further unpack the two WD-11 Radiotrons from their cartons. Turn the knob marked "Battery Setting" near the left rear corner of the panel as far to the left as possible until the pointer rests on "OFF". Then insert the WD-11 Radiotrons in their sockets which are located just below the oval hole in the panel. The pins on the bases of the Radiotrons fit into sliding contacts which are located in holes in the socket panel. The sockets are so arranged that the large pin will be toward the front of the set. The socket panel is flexibly supported on rubber but is equipped with stops which prevent motion too far vertically in either direction. **Be sure to push the Radiotrons down into the sockets as far as they will go, that is, until the molded base of the Radiotron rests upon the socket panel.** Then turn the "Battery Setting" knob to the right until the pointer comes between the two "Ts" of the word battery. Look directly down into the Radiotrons to see that the filaments of both are glowing at a dull red heat. If either one fails to glow see that it is firmly in its socket and if the trouble still exists, interchange the Radiotrons. Both must glow or the set will not operate. If one cannot be made to glow it indicates that the filament has been broken and it must be replaced by a new one. Having determined that both filaments glow turn the "Battery Setting" knob back to "OFF".

Then proceed with the "B" battery shown to the right in Fig. 2. This consists of two 22½ volt blocks which are designated "B Battery". Using a short piece of wire connect one end to a center terminal (positive) of the "A" battery and connect the other end to the negative terminal of one of the "B" batteries. Using another short piece of wire connect one end to the positive terminal of the same "B" battery and connect the other end to the

negative side of the second "B" battery. Now find the cable conductor which has a maroon braid and a tag marked "+20 B". Connect this to the positive terminal of the first "B" battery. Also find the conductor with the red braid and a tag marked "+40 B". Connect this to the positive terminal of the second "B" battery.

The "C" battery is shown at the extreme left and consists of a single dry cell similar to one of the units of the "A" battery. Using a short piece of wire, connect one of the outside terminals of the "A" battery to the center terminal of the "C" battery. Then find the cable conductor which has a black field with a green tracer and connect it to the outside terminal of the "C" battery.

The ground wire should be connected to the negative terminal of the first "B" battery or to either positive (center) terminal of the "A" battery, whichever is most convenient. This wire should run as directly as possible to the ground clamp.

The antenna lead from the lightning arrester or switch should be a piece of flexible wire long enough to reach any one of the antenna posts at the right side of the set.

Great care should be taken to keep all connections tight, as failure to do so may result in objectionable noises or render the set inoperative.

## OPERATION

### Controls

**Battery Setting**—The control so marked serves to turn on and regulate the current to the filaments of the Radiotrons. When the set is not in use the pointer of this control should always be turned as far to the left as possible, so that it points to "OFF". When it is desired to operate the set, turn the "Battery Switch" knob to the right until the filaments glow at a dull red color.

**Station Selector**—The control so marked serves to adjust the tuning circuit so that the set will respond to the desired wavelength.

**Amplification**—The control so marked adjusts the regeneration and thus regulates the sensitivity and selectivity of the set.

**Antenna Binding Posts**—There are two types of circuit available. One is a straight single tuning circuit noted for its sensitivity and ease of operation. The other is a type of coupled circuit affording more selectivity. Either may be had at will by connecting the antenna to the proper binding post and putting the link in the proper position. Fig. 3 shows the suggested combinations which have the following properties.

**No. 1**—Antenna on 4, link open. This is a single circuit connection which on an average antenna will cover the approximate wavelength range of 200 to 360 meters corresponding to a frequency range of 1500 to 830 kilocycles.

**No. 2**—Antenna on 3, link open. This is a single circuit connection which on an average antenna will cover the approximate wavelength range of 250 to 480 meters corresponding to a frequency range of 1200 to 625 kilocycles.

**No. 3**—Antenna on 2 and 3, link open. This is a single circuit connection which on an average antenna will cover the approximate

wavelength range of 315 to 560 meters corresponding to a frequency range of 950 to 535 kilocycles.

No. 4—Antenna on 2 and 3, link on 4. This is a closed single circuit which on a very small antenna, such as an indoor one, will cover the approximate wavelength range of 290 to 575 meters corresponding to a frequency range of 1070 to 520 kilocycles.

No. 5—Antenna on 1, link on 4. This is a selective single circuit connection which on an average antenna will cover the approximate wavelength range of 195 to 375 meters corresponding to a frequency range of 1540 to 800 kilocycles.

No. 6—Antenna on 1, link on 3. This is a selective single circuit connection which on an average antenna will cover the approximate wavelength range of 310 to 640 meters corresponding to a frequency range of 970 to 470 kilocycles.

### Finding Signals

Select a suitable antenna connection according to one of the combinations shown in Fig. 3. Generally the first trial may be made using the single circuit connection with the intermediate wavelength range, the second connection from the left. Push the telephone cord tip terminals into the holes at the left of the panel above and below the word "Phones". The contact toward the rear of the panel is positive. Turn the "Battery Setting" to the right until both filaments glow at a dull cherry red. This should happen by the time the pointer reaches the last letter of the word "Battery", when the cells used in the "A" battery are fresh. Set the "Amplification" at "3" and move the "Station Selector" slowly back and forth over the scale. If signals are heard, carefully adjust the "Station Selector" until the signals become loudest and then turn "Amplification" to the right when the signals should become still louder. Do not turn amplification to the point where the signals become distorted or where whistles and howls are produced. If no signals are heard the first time, turn "Amplification" one-half division to the right and try again. Turn "Station Selector" slowly and listen carefully as signals are frequently very weak when first received. Continue this process until results are obtained. If the first antenna combination fails to give results try another.

When "Amplification" is turned too far to the right the set will oscillate. This condition will be apparent by a breathing noise and usually by whistling noises, the pitch of which varies as the "Station Selector" is turned slightly. The proper operating point is with "Amplification" just below the point at which the set will oscillate. After a little practice it will be possible to tell when this condition occurs as it is the most sensitive condition and static noises will be loudest. Then the proper procedure when finding signals is to turn "Amplification" up to this point and then adjust the "Station Selector" until signals are heard. Careful adjustment of both "Station Selector" and "Amplification" will be needed to obtain maximum strength of signals.

The maximum sensitivity is obtained when a regenerative set is adjusted so that it is just ready to oscillate. The ease with which a set oscillates depends upon the antenna and the condition

of the detector Radiotron. In case it becomes impossible to make the set oscillate it is an indication that the antenna or ground should be improved, that the detector Radiotron should be replaced, or that the first "B" battery is becoming discharged. To determine whether or not the set is oscillating place a finger upon any one of the antenna binding posts thereby stopping oscillation and causing a distinct click in the headset which will be repeated when oscillation starts upon removal of the finger.

In case it is impossible to make the set oscillate on all antenna combinations, disconnect the maroon cable lead (+20B) from the positive terminal of the first block of the "B" battery and connect it to the positive terminal of the second block, (+40 volts).

When a set is oscillating strong whistling noises are produced not only in your own set but in your neighbor's, which vary in pitch as the "Station Selector" is turned. Also, much of the static and other interference is stopped but a characteristic breathing sound is produced. It becomes much more difficult to tune to a station and it is impossible to get good, clear reception.

If the receiver is allowed to oscillate it will disturb other nearby receivers. Therefore care should be exercised to avoid the oscillating condition, and whenever the receiver does oscillate accidentally, to stop immediately by turning the amplification control back to the proper point.

### SOME CAUSES OF FAULTY OPERATION

**Filaments fail to glow**—"A" battery may be exhausted: One of the leads may be disconnected: One Radiotron or more may not be making contact in the socket: The filament may be broken: Connections may be loose.

**No sound is heard**—The filaments may not be lighted: The "B" battery may be disconnected or the leads reversed: The "B" battery may be exhausted: The leads to the head set may not be connected: The "C" battery may be disconnected. If slight noises are heard and no signals, no station within range is operating.

**Howling noise**—The antenna may be disconnected or the link may be open when it should be closed: "Amplification" may be turned too far to the right: The "C" battery may be exhausted.

**Music or speech distorted**—The bias battery connections may be reversed: The "B" battery may be exhausted.

### MAINTENANCE AND REPLACEMENTS

**Radiotrons**—Occasionally a Radiotron will become inoperative on account of a broken filament or a cracked or broken bulb. When this happens it should be replaced by a new one. After many hours of service a Radiotron will occasionally lose its sensitivity. It will pay to obtain a new one when this happens.

**"A" Battery**—When the dry cells used for this purpose become discharged to the point where they will no longer heat the filaments to the proper temperature they should be replaced by new ones. The same directions should be followed as for a new installation. Always remove Radiotrons from their sockets when replacing batteries.

**"B" Battery**—It is rather difficult to know when these batteries are exhausted, as there is no external indication except weakened signals. The best way is to obtain a reliable voltmeter which will indicate up to 100 volts at least and take weekly readings of your batteries. Discard each block when the voltage per block falls to 17 volts.

**"C" Battery**—This battery should be replaced whenever its voltage falls below 1.2 volts. The battery of the kind recommended should last for at least a year but a good plan is to use it for one of the new "A" battery cells and replace it by a new one whenever the "A" battery is replaced.

**General**—When asking for information about or for repair parts for or when reporting troubles with this set please mention the serial number which may be found on the bottom of the box.

A complete diagram of connections is given in Fig. 4.

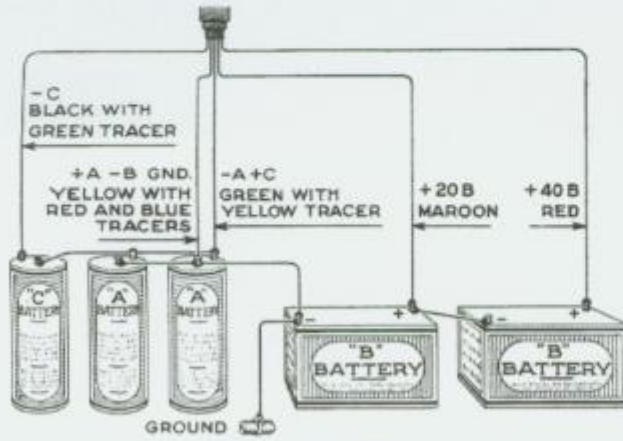

Fig. 2—Battery Connections

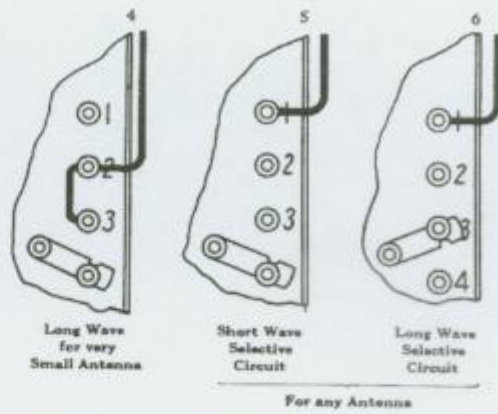
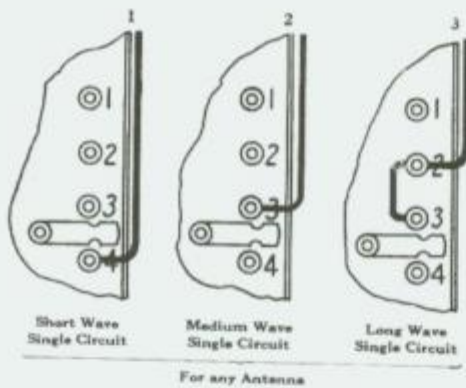

Fig. 3—Showing Antenna Connections to Different Binding Posts

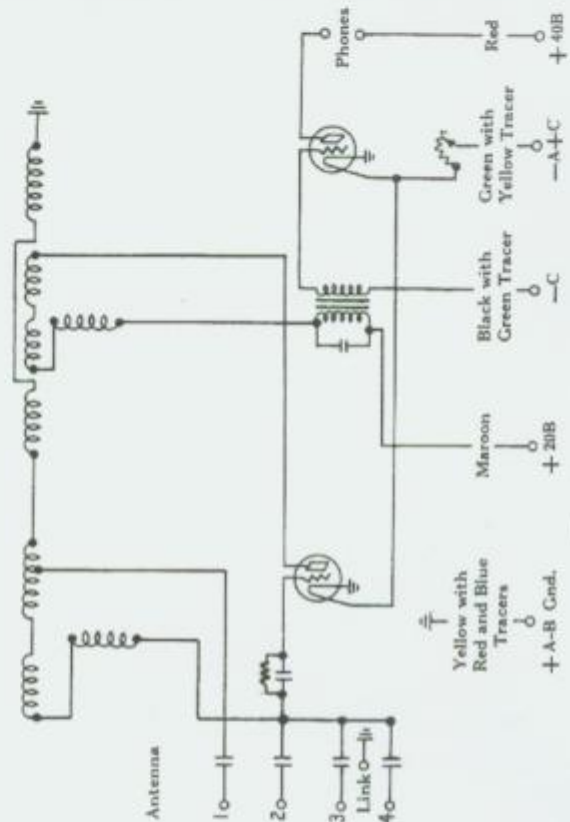

Fig. 4—Diagram of Connections